

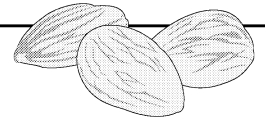

# KNEWSLETTER IN A KNUTSHELL



- ✓ Novelty Cutlery Co
- ✓ US Military Cutlery
- ✓ A Little Advertising will Surprise You
- ✓ Show Application
- ✓ Club Knife
- ✓ Mike & Barb's Corner

Our international membership is happily involved with "Anything that goes 'cut'!"

## October 2002

# THE NOVELTY CUTLERY COMPANY By Cindy Vignos

In the late 1800's, the emerging political career of William McKinley brought national attention and industrial growth to his hometown of Canton, Ohio. The Novelty Cutlery Company was formed in 1886 by Canton's postmaster, the enterprising Augustus Vignos. This small company soon became known world-wide as a manufacturer of quality, transparent-handled knives.



Major Augustus Vignos

Augustus Vignos was a ambitious individual who overcame financial adversity and physical challenges to become a successful entrepreneur. The son of European immigrants, he embraced and truly epitomized the American Dream. This is the fascinating story of his life.

Augustus' father, Joseph Vignos, traveled to the United States in 1831 at the age of 18 from the Chevanne-les-Grands region near Belfort, France. Upon landing in New York City he met Theresa Frantz, another French immigrant who had just arrived with her

family. The two were married a few years later and settled in the rural community of Louisville, Ohio...a sparsely-populated area inhabited mostly by other French immigrants.

Although Joseph was skilled in the trade of carpentry and cabinet making, he decided to pursue the hotel and restaurant business. Louisville was situated on a former Indian trail that had become one of the main routes westward. Travelers heading toward the new frontier were in need of accommodations, and at the time, there were only a few buildings in the town. Joseph seized the opportunity and opened a tavern and livery stable in a log building in the town square. Replaced by a brick structure in 1849, the building is still standing and has recently undergone an extensive renovation by its present owner, a local grocer.

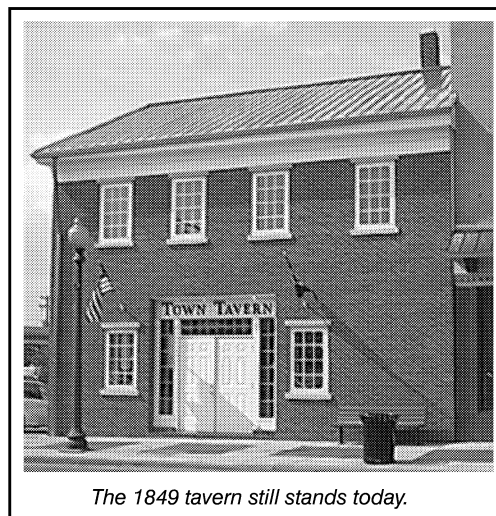

The 1849 tavern still stands today.

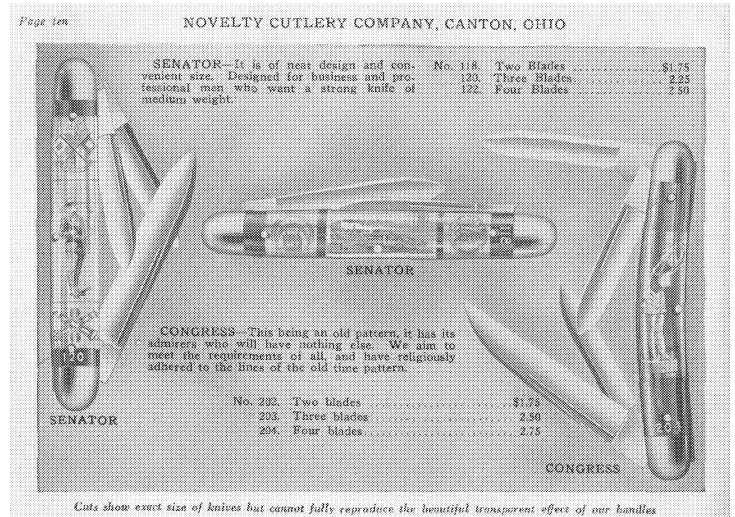

Cuts show exact size of knives but cannot fully reproduce the beautiful transparent effect of our handles

Augustus Vignos was born in 1838. He attended local schools and worked at his father's hotel -running errands and doing odd jobs. He was familiar with a 40-mile radius of the surrounding countryside, and often earned money driving travelers along the roads and trails.

An inclination for music and militia led Augustus to perform in local drum corps and drill teams. Although he was musically gifted, his parents did not support this aspiration, and he was compelled to practice in the barn. In 1861 he responded to President Lincoln's call for volunteers and enlisted in the Union Army as a musician. It was unknown to anyone at the time that this endeavor would lead to a successful military career.

Augustus' regiment -Company I of the 19th Ohio Infantry -was organized in nearby Alliance, Ohio, and participated in a number of important battles. During the violent fighting at Shiloh, Augustus was stricken with typhoid fever and was sent home to recuperate. Anxious to return to the War effort, he began working ambitiously as a recruiter. He enlisted 70 men into a new regiment and was assigned as their captain. Although only partially recovered from his bout with typhoid, Augustus organized the 107th Ohio Volunteer Infantry in 1862, and they went off to join the fighting.

Continued on page 4

# Knots on United States Military Edged Cutlery

by Frank Trzaska

## Canopy Breaker Tool

While plugging along on the above research, as so often happens, I tripped over another item I have wondered about, the Canopy Breaker Tool. This heavy piece of solid steel is called a knife

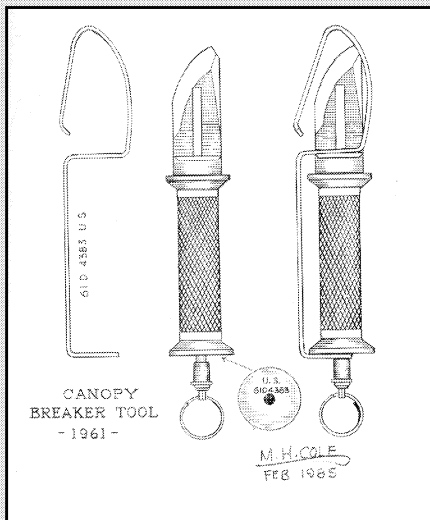

by some. The heavy piece of equipment with circular knurled handle and welded blade is government part number 61 D 4383 which crosses over to the NSN of 1680-00-083-7011. Stocked by the Defense Logistics agency, the knife has a government cost of \$84.84 each with holder. I wouldn't give you \$10.00 for it as a knife; but if trapped inside a cockpit, that heavy weight tool would indeed be something I was looking for. This was an instrument really designed as a pry bar, not like the so called Quartermaster knives. The heavy pommel could strike the plexiglass while the knife edge would extract or pry out the pieces. Stocked by the Air Force as well as the Navy, these items if needed can be procured thru Weber Aircraft Inc., Special Products Division located in Fullerton, Calif. Weber Aircraft was formerly a division of Kidde Inc. They currently operate under the CAGE Code of 92824 for those so interested in further digging. I have seen two types of these knives in the past few years, one with the welded on blade and another which seems to be completely machined from a solid block of steel. While I occasionally see the knives for sale, the mounting brackets are very seldom seen. I guess it's easy to swipe the knife but a real bear to get the bracket out?? One I had purchased some time ago had several coats of paint on it. Scratching down through the layers, I found white, green (actually olive drab) and black. I'm not sure of the reason behind this, but it seems to have been done by someone other than the factory as the paint

coatings were of inconsistent thicknesses and texture. Maybe to match with the curtains and the rug??

## Nothing To Do With Knives Again

Take that bet with your friends or co-workers and win it big. It seems the more I ask people the answer is always the same, was George Washington the first President?? Everybody looks at you funny and answers yes, well the correct answer is no he was not. In fact there were seven (7) before him. The official title was "President of the United States in Congress Assembled." The position was the presiding official in congress, not what we currently think of as President, but it was at the time. They were: John Hanson (1781), Elias Boudinot (1783), Thomas Mifflin (1784), Richard Henry Lee (1785), Nathan Gorman (1786), Arthur St. Clair (1787), and Cyrus Griffin (1788). They all served under the "Articles of Confederation" BEFORE the present Constitution was adopted. That is the cut off date that Washington was elected and the counting began.

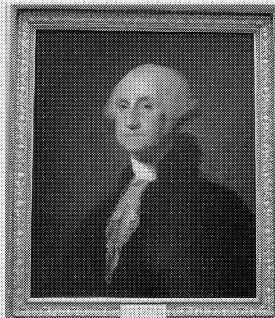

## Watch Your Back

While we are talking about presidents, did you notice that when George W. steps off of "Marine One", he is given the perfect salute by the Marine NCO in Dress Blues just like every other President before him was. But things have changed just a little. Watch closely as the Marine does the perfect "Right Face" as George W. walks past him. This was NEVER done with the previous occupant of the White House. It is an old tradition of the Marine always facing the higher ranking official to await a command, even if it is the commanders back. It may have been a small victory, but the Marines NEVER faced the last guy and really didn't care what he thought of them. I don't think the media ever picked up on it, but it made me smile a bit.

## Mark 2 Markings

We constantly see Mark 2 knives advertised as "Vietnam" issue pieces. Well we know better as some of these knives were not yet made when the United States withdrew from the war. They may very well have been in Vietnam but not while the U.S. Forces were fighting there! So with that said we can say that any Mark 2 with the markings of U.S./Camillus or U.S./Ontario were not in Vietnam when the U.S. fighting was going on. The U.S./Camillus is very close as the switch over to this marking occurred on 1 Feb 1974. So if you choose the 1975 ending to the Vietnam War, this is a Vietnam era knife. If you choose the 1973 ending version, it is a post war knife. It certainly did not ride on the hip of a U.S. serviceman humping the boonies, that was over by then. These knives are often attributed to S.O.G. troopers and such, baloney, that is marketing hype or to put it in not so

politically correct words "a lie." I have seen these knives in large publications with captions saying something about "Vietnam" like the knife was there. This just perpetuates that lie and continues the story. If gone uncorrected, it becomes the "truth" as the story is told and retold. Don't buy it and don't spread it. The U.S./Ontario marked knives were first made in 1980 so if you heard about this one being in Vietnam, quietly excuse yourself and make tracks for the door, it's getting deep in there. Although Ontario did have earlier contracts with the Jet Pilot Knives, the contract for the Mark 2 came much later. As for the U.S./M.S.I. marked knives I still haven't a clue as to who they were/are? Do you?

## Maxim Scabbards

The scabbard referred to above assigned to Maxim was for the U.S. M1917 bayonet. While the name Maxim is usually associated with the German fielded Machine Gun of the First World War, it must be remembered that Hiram Percy Maxim was an American inventor living in Hartford, Connecticut. The patent application was filed on 20 June 1917 under serial number 175,762. The final Patent was assigned 20 Aug. 1918 under Patent number 1,276,554. Three detailed drawings accompany the Patent. This is for the early style scabbard with the Model 1910 belt hanger wire with the leather hanger as made by Graton & Knight and Jewell in 1917. By the time the Patent was granted, the U.S. had already abandoned that style hanger and moved onto a stronger arrangement. Over three million of these scabbards were made, but the Maxim designed model with the leather belt hanger is exceedingly

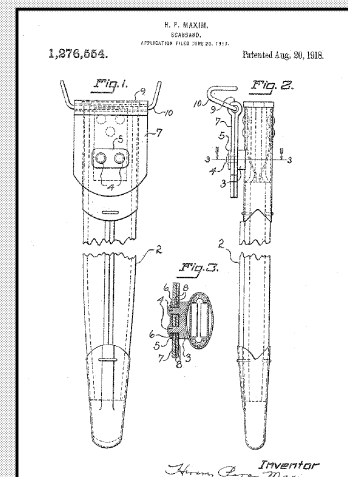

difficult to come by in nice condition. It is assumed very few were made before the U.S. switched production. Incidentally the Patent was assigned to the Maxim Silencer Company, creators of Maxim's other toys he supplied to the Ordnance Department. Sir Hiram had a lot of equipment on the battlefields of France, on both sides no less! I wonder how many others can proclaim that?

Frank Trzaska - [trz@mcsystems.net](mailto:trz@mcsystems.net) & web site [www.usmilitaryknives.com](http://www.usmilitaryknives.com)

# OKCA Knews and Musings

*ibdennis*

## Lodging.....

Elayne and I got it into our heads that we wanted to travel and take in a Knife Show. Little did we realize the hurdles and hoops that it took to make such a trip. We have attempted to make it easy for our attendees to come to the Oregon Knife Show but never got too much involved in planning from the other end. What an eye opener. As a result we are streamlining the information we pass out to people that are interested in coming to Oregon in April.

The lodging was the largest pain. Where to stay and where not to stay. The recommendations were the usual big names with the big per nite price tags. And an additional \$15 for our pooch. Well over the \$100 mark for a three star joint. Whatever traffic will bear. The show apparently had no partnerships with any of the motels, leaving the visitor to their own devices. In fact some of the places were five to ten miles or more away.

With this in mind I renewed our partnership with several motels in the area. The idea was that if I would stay there, I felt our membership and visitors would also. The idea of a partnership is to get a break on prices and also establish a path of communication were a problem to develop. It also serves to have the motel take interest in our group and cater to them as best they can. In many cases this also allows us to block out rooms for our guests only, which assures space if another event is happening at this time.

Our best partner over the years has been The Valley River Inn. This is a four star motel with ambience that doesn't stop. Mention the Oregon Knife Show and the rates dip below the \$100 level. Don't mention the Knife Show, and you will pay standard rates. The service is worth the standard rates but remember we are partners so group rates serve us both. We have filled the Valley River Inn every year and anticipate doing it again this year. The word is early reservations. If you experience a problem, let us know, for it is the only way that we can fix it.

Another new place to consider staying is the Red Lion Hotel. We have made arrangements with these people so this is yet another consideration. We have also made arrangements with the Courtesy Inn this year for the budget minded. Seven blocks to the Convention Center if you are a walker. This might be a good consideration for the Winter Mini Show too if you are planning on staying over a night.

Accommodations we support are listed on this page. When should you make reservations for the April Show? Today is a good idea.

## Articles in our Knewsletter...

**Gerry Parmley** had a Novelty Cutlery knife listed on eBay and as a result was contacted by Cindy Vignos, a great-great granddaughter of Major

Augustus Vignos. As a result of this communication, Cindy Vignos wrote the enclosed article about her family heritage and the knife company associated with the family. This "especially for us" article is what makes the Oregon Knife Collectors a special organization. It is also what turns my crank to continue making this Knewsletter happen. Keep those articles and stories coming.

## Monthly Meeting Place has changed for October...

The October meeting will be held at G. Willicker's this month. This restaurant is on 440 Coburg Road and offers easy and abundant parking along with food choices that should please all. You can order your dinner at the counter and join us in the meeting room in the back. Yes this is the same place (different management) that we were at years ago. The menu has changed and our experiences to test it out have proved quite good. Come join us.

## The Winter Mini Show

We have had several inquires during the summer about the Winter Mini Show. The date is December 14, 2002. Contact Mike Kyle at (541)998-5729 to reserve your table. You may also email Mike at a-doxiex2@att.net.

We will again enforce the rule that you must have your table open the whole time of the Show hours (8 to 4) or suffer the consequences. We advertise these hours so we should be there the whole time. What are the consequences? You do not want to know!

## The 2003 OKCA Club Knife

The OKCA 2003 Club Knife will be a custom knife designed and made by Butch Vallotton. An order blank can be found in this Knewsletter. We will only offer one knife per member. There will be 50 knives offered and after 30 days we will open it up to additional knives to those who want more than one. I, for one, will order two when available as I see one in my collection; and one in my pocket. This is a fantastic knife.

Butch was at the last meeting and the oohhhs and ahhhhs were heard repeatedly throughout the night as people got to see and handle the prototype.

The handles are honey coloured bone; the hollow ground blade is 440C; it has a signature forged over liner lock; titanium liners and thumb stud. The handle is 3-1/2" (8.9 cm), the blade is 2-1/16" (6.8 cm) and overall is 6-1/8" (15.5 cm) The knives will be serial numbered and will have the OKCA logo etched in the blade.

We are currently working with Butch to offer another handle material and to also offer to Oregon residences a special enhancement to this knife at the same time. It is only talk at this time.

Remember that the sales of these knives support

the Club and also put a quality "one of a kind knife" in our member's hands.

## Display Cases for the April Show

At the last Show we experimented with display cases which could be rented by table holders. We guessed on the amount, and a dozen cases did the trick. We contacted the case maker, and he is willing to do this again for the April 2003 Show. So if you want to take advantage of this, let us know as soon as possible. These custom made lockable wood cases are 24" x 30" and can be rented for \$30 for the three days. A small price to pay against shipping or having to haul a display case to the Show.

## Renew your 2003 OKCA Membership and.....

Get your table application in soon. The table deadline is December 15<sup>th</sup> for those of you that had tables last year.

## Places to Stay when attending the Show

**The Valley River Inn** -(800) 543-8266 -(541) 687-0123 -Our top recommendation. Fills up fast. A quality place to stay. Official home for folks away from home visiting the Oregon Knife Show. Special Show rates if you mention the OKCA Show.

**The Campbell House** - A City Inn -(800) 264-2519 -(541) 343-1119 -Classic Hospitality. A very unique experience. Top quality.

**The Red Lion** - (800) Red Lion - (541) 342-5201 - Not far from the Show and a great place to stay. Mention the Knife Show for the special rates.

**Courtesy Inn** - (888) 259-8481 (541) 345-3391 The closest motel yet to the Knife Show. A Budget motel and special rates if you mention the Knife Show.

Letting these places know that you are with the Oregon Knife Collectors should get you a special rate and it helps to promote our Show.

Self-contained motor homes can be parked in the parking lot at the Convention Center. There is a charge of \$15.00 per night, or \$50.00 for three nights or more. Register with the office.

Also for motor homes or campers:

Creswell KOA Mobile Home Park (800) 562-4110 -(541) 895-4110  
Premier RV Resorts (541) 686-3152  
Eugene Camping World & RV park (800) 343-3008 -(541) 343-4832

*ibdennis@earthlink.net*  
*ibdennis@oregonknifeclub.org*  
<http://www.oregonknifeclub.org>

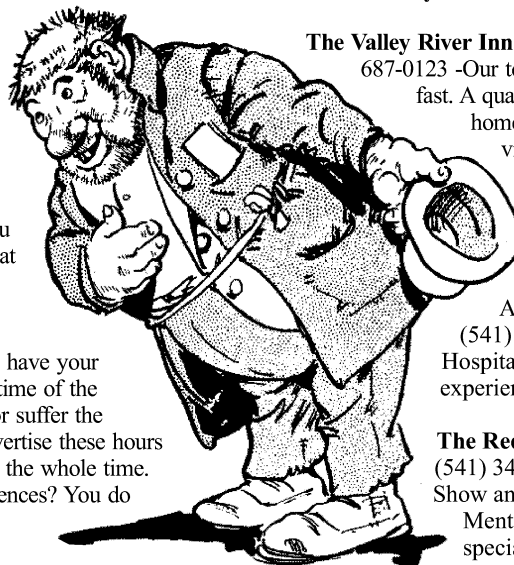

# The Seek-re-tary Report

by *elayne*

We had our first meeting of the new season September 12, 2002. There were 28 present. Some table reservations have been paid to the total of 121 and 40 memberships were paid during the summer. Thank you for the respite. The most recent Knewsletter has been mailed and the memberships and table reservations have started to increase in number.

Michael Kyle will coordinate the December show (December 14-Lane County Fair Grounds). We expect about 90-100 tables. The hours will be 7:00am to 4:00pm. We plan for a potluck dinner after the show. We had 79 in attendance last year. We will have a donation box for the Marine's Toys For Tots program. Please call Michael (541)998-5729 to reserve your table for December. No charge for the table to Club members. No charge for admission to visitors.

We will have an AI Mar folder for the display award knife. Wayne Morrison will coordinate the handling, scrimshanding and engraving. Please contact Wayne (541)942-1374 if you can donate your talents to enhance these knives.

Larry Criteser will oversee the grinding competition. We want the grinders to volunteer to finish the knives so we can present them as display award knives the following year.

Butch Vallotton has volunteered to produce the Club knife for 2003. The order form will be published in the next Knewsletter. Thank you, Butch.

The Website has undergone some changes. Our ISP has changed and naturally that meant everything that had worked didn't quite act the same with the new ISP. All should be ok now but check it out for yourself. We are very proud of our Website and try to keep it as current as possible.

Meeting adjourned for Show and Tell.

PS-We have arranged for the October meeting to be at G Willikers Restaurant. It is located on Coburg Road in Eugene. See you at the meeting October 10, G Williker's Restuarant, 440 Coburg Road, Eugene, Oregon.



## Novelty Cutlery *Continued from page 1*

The new regiment participated in several campaigns, then joined the fighting forces in Gettysburg, PA. It was here that Augustus received the injury that would drastically affect the rest of his life. While awaiting orders on Barlow's Knoll, Captain Vignos was struck by a cannonball, and his right arm was shattered from elbow to wrist. Due to the horrible fighting, there were thousands of wounded soldiers; and Augustus waited three days before receiving treatment. By that time, serious infection had led to gangrene, and the arm had to be amputated just below the shoulder. He was given up to die, but his strong will prevailed once again.

Augustus was sent to a nearby farmhouse and was under the care of Rebecca Price. She took pity on Augustus and violated orders from superiors to aid him. She found new clothes for him (his blood-soaked uniform had to be burned) and made arrangements for him to board a freight train out of Gettysburg. Afterwards, Augustus made numerous attempts to locate Rebecca and carried her photograph with him for 44 years, in the hope of finding someone who might know her whereabouts. Finally in 1905, they were reunited at a Grand Army of the Republic (G.A.R.) Reunion in Saratoga, New York.

Despite opposition from doctors, Captain Vignos rejoined his regiment. He was promoted to the rank of major in 1863. Although his wound was not completely healed, he led the regiment for another 10 months. He finally resigned following an accident that nearly cost him his remaining left arm, and he received an Honorable Discharge. In 1887, Major Vignos assisted with the unveiling of a memorial marker bearing his name, commemorating the position defended by his regiment during the Battle of Gettysburg. Now a tourist attraction, the marker stands as a testament to an impressive military experience for a patriotic young man who enlisted as a fife-player! For the rest of his life, Augustus was fondly referred to as "The Major" by family and friends.

Following his military service, Augustus returned to Louisville and married Phoebe DeVinney, an Irish immigrant to whom he had become engaged prior to leaving for the War. She was employed as a Catholic school teacher, and the rules were "bent" to allow her to continue teaching until a qualified replacement could be found (at the time, school teachers were not allowed to marry). The couple eventually had eight children, although three of them died from illness

during their childhood.

Despite his impressive War record, Augustus had

difficulty finding suitable employment because of his disability, and he was forced to take on odd jobs. He and Phoebe moved to Iowa and invested in a brewery business, but a fire destroyed the property; and they returned to Louisville -discouraged and deeply in debt. To provide for his growing family, Augustus worked as a janitor and night watchmen. He also mowed lawns...a challenging task for a one-armed man using a push mower! Despite his efforts, the family's financial woes continued. Augustus became interested in local business development but did not have the capital to invest.



Phoebe DeVinney

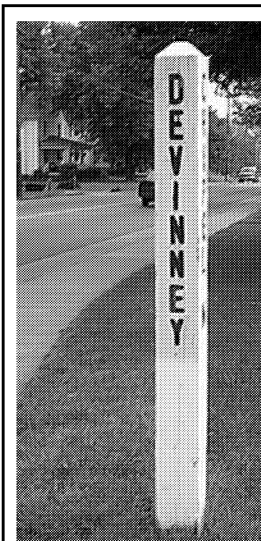

Street named after the family of Phoebe DeVinney

*Continued on page 6*

# A LITTLE ADVERTISING WILL SURPRISE YOU

Merle Spencer

I certainly had a good time at the April Show – all three days. I had to leave every couple hours to take my wife to a different part of Eugene so I could spend some more time at the Show. I kept checking on the display award case to see if my knife contribution was there yet. Finally it was, the last one in the case. I had run into a few difficulties in finishing it on time, but eventually delivered it to Dennis a week or so before the Show.

On Friday of the Show I was wandering around and stopped to talk to Ed Fowler. He indicated he would like to go across the hall to see someone, but the person who was going to tend his table hadn't put in an appearance. I told him I would be glad to watch his table since I didn't have a table of my own and planned to attend all three days. He was pleased. So I sat there and watched people pick up those expensive knives and put them back down. I wondered what I would do if someone decided to buy one. He hadn't left any change or receipts, and his book was also for sale on the table. One person bought a book and paid an even dollar amount even though he had a little change coming. I counted the knives each time the table cleared of lookers (I knew how many were there).

Along about this time along came a young lady who introduced herself as Tracy Wierzba, advertising sales person for *Blade Magazine*. She said she wanted to see Ed. I remembered Ed was a field editor for the magazine. I had also noticed the Blade table display earlier. I told her he would soon be back as he had just gone to see someone. We talked for a bit and I asked if she read the OKCA Newsletter and handed her the April issue I had with me, containing one of my articles.

As a result of our conversation, she invited me to send her some pictures of a few of my knives and a short bio for a possible spot in the magazine. I explained that I was a hobbyist and did not sell knives, but she encouraged me to submit the material, anyway. Well, since I had belonged to a writer's group and this was an opportunity, I sent in the material.

After a couple emails on picture quality and the need to send actual photos, the material seemed suitable and was forwarded on to the managing editor to be considered for "Knifemaker Showcase." I indicated there were no prices, as I do this only as a hobby. I watched the issues of *Blade* and saw nothing of my stuff for several months. In early August I emailed Tracy that I hadn't seen any result, nor had my prints been

returned. Her reply stated that I would be featured in "Knifemaker Showcase" in the next issue of *Blade*, and she would see that I got my prints.

The November issue of *Blade* came in the mail one morning in late August, and there was my picture and a picture of one of my knives. At the end of the description it said "Prices n/a." That afternoon a gentleman called me from Ohio and wanted to know a price so he could order a knife. I told him completing knives was a hobby for me, and I didn't make them to sell. I did recommend a knife maker friend, however. I understand a knife was ordered. So... advertise, guys.

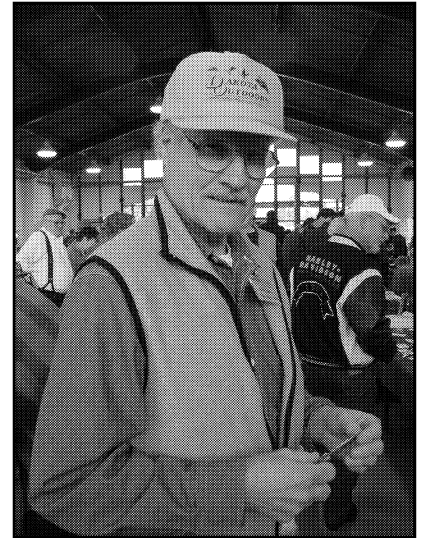

## OKCA Club Whot-zits & Whos Zits

### Darold (Ole) Olson

President (541) 726-7503

### Loy Moss

Vice President (541) 747-7600

### Elayne Ellingsen

Sec/Tres. (541) 484-5564

### Michael Kyle

Master at Arms (541) 998-5729

### Dennis Ellingsen

Show Coordinator (541) 484-5564

Knewsletter by elayne & dennis

Cut-toons by Judy & Lonnie Williams

Web page <http://www.oregonknifeclub.org/>

Club e-mail [okca@oregonknifeclub.org](mailto:okca@oregonknifeclub.org)

OKCA, PO BOX 2091, EUGENE, OR 97402  
(541) 484-5564

Copyright © 2002 Oregon Knife Collectors Association. No part of this newsletter may be reproduced without permission of the OKCA. Email [info@oregonknifeclub.org](mailto:info@oregonknifeclub.org). Layout and printing by Insta-Print - 1208 W. 6th - Eugene, OR 97402

## Cut-toon

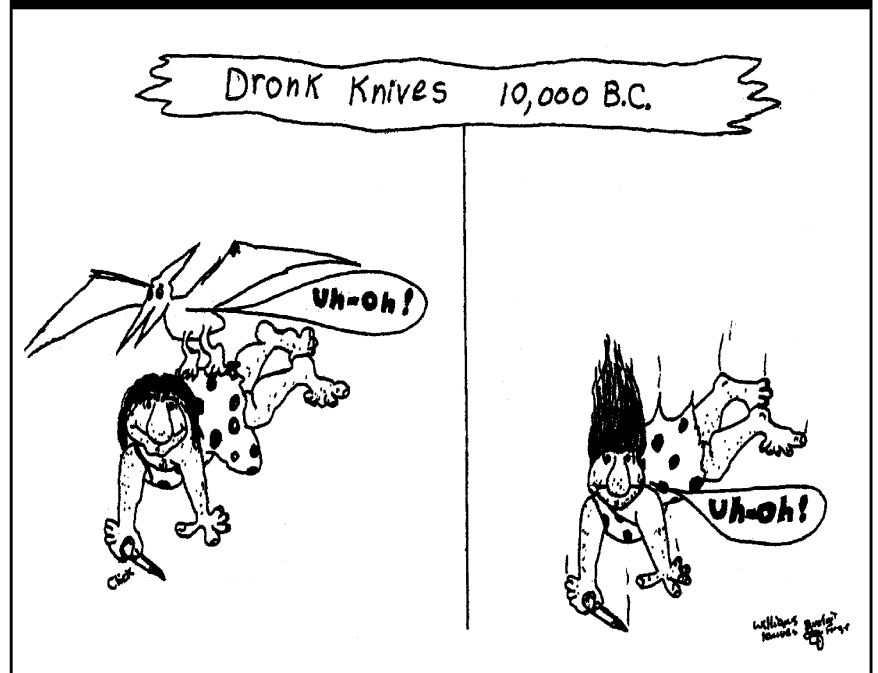

**Novelty Cutlery** *Continued from page 4*

The situation came to the attention of William McKinley, a lifelong friend of Augustus' and also a discharged Army major. Augustus had campaigned for McKinley when he ran for political office. While serving in the House of Representatives, McKinley asked President (and fellow Republican) Rutheford Hayes to appoint Augustus as Canton Postmaster in 1877. During Augustus' term in office, daily home mail delivery was established in Canton. In 1886, Augustus and another postal employee named Alvin Hurford formed the Novelty Cutlery Company. Men of all trades carried pocket knives at this

several factors...

The company prided itself in the quality of materials and workmanship that went into each knife. Canton's growth as an industrial center made it possible to obtain top-grade nickel and steel locally; the blades were forged on-site. Collectors recognize the trademark triangle engraved with the name VIGNOS on the blades of Novelty knives. The handles were deemed "indestructible" and every knife came with a warranty.

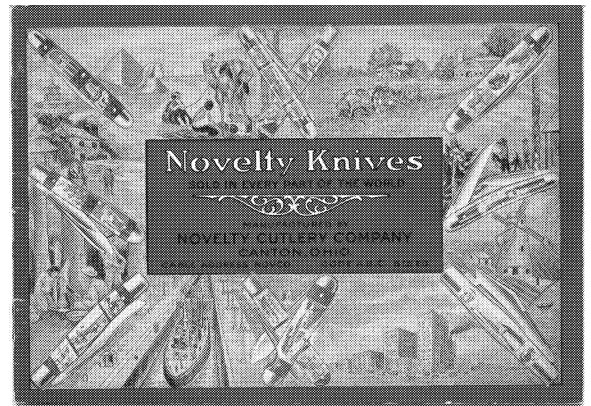

NOVELTY CUTLERY COMPANY, CANTON, OHIO Page nine

**COMPANION—No. 472.** Two blades one pocket and one pen ..... \$1.75  
with chain ..... \$1.95

**STURDY KNIVES FOR STURDY BOYS**

**SCOUT KNIFE.**  
No. 185. This knife built for service and rough usage, one master blade extra heavy. Each special blade will do the work for which it is intended. Bal in steel, to attach to chain.

No. 185 A REAL SCOUT KNIFE. 5 3/4 inches long ..... \$3.00  
No. 185-C With Compass in Handle ..... 3.50

**CRACK-A-JACK**  
No. 273 — Two blades ..... \$1.75  
With chain ..... 1.95

SUNK JOINTS SAVE the WEAR on POCKETS

time, and the company manufactured unique transparent-handled knives which could be ordered to personal specifications. Augustus bought out Hurford's portion of the firm in 1892, and the business continued to grow steadily upward in financial success. Augustus began promoting the knives in international publications, and orders arrived from all corners of the globe. An expanded facility was constructed to accommodate the increased business. Starting with only a handful of employees, the company's payroll later included an average of 80 people. The success of the company was the result of

All Novelty Cutlery knives were made-to-order from a wide selection of handle styles and blade varieties. The customized knives became popular for gift-giving and commemoration of important events, in addition to their use as a means of identification. The promotional advertising knives also became especially popular. Some risqué knives featuring photos of "bathing beauties" have been seen in modern collections, although these choices are not pictured in the Novelty Cutlery catalogue!

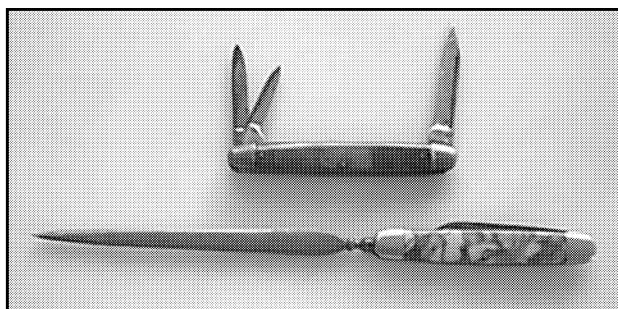

Following the assassination in 1901, McKinley's body was returned to his hometown of Canton, and Augustus acted as a pallbearer in the funeral. In photographs of the funeral, a one-armed man can be seen in the procession as it passed through the city. The McKinley Memorial Knives were created in remembrance of Augustus' friend, to whom he owed his

financial recovery. The knives featured photographs of William McKinley, his widow, Ida Saxton McKinley (also a Canton native) and the McKinley Monument which was located near the new Novelty Cutlery manufacturing facility. Commemorative items honoring the martyred president were very popular at the time. In 1901, Canton doctor, W.S. Carnes, began buying Novelty Cutlery stock; and he became company president in 1908. During this time the company was renamed The Canton Cutlery Company. Dr. Carnes began experimenting with alloy steels, in the hopes of producing a blade that would be strong, yet flexible. He traveled around the country giving lectures about his discoveries to metallurgists, technical societies and other specialists of the steel industry. He sold the company to Car Van Steel Products in 1927.

CANTON, OHIO Page seven

The knife shown on this page with picture of our President, Maj. A. Vignos, and our factory shown under the handle, is the largest perfect working knife ever made. Its weight is 55 lbs. and length, blades open, 5 ft. 1 in. It is a perfect facsimile of our Novelty style and merely demonstrates the ability of our factory to do great things.



During World War II, steel became scarce. Dr. Carnes sold his leftover alloy to a local carver and knife producer, Ernest Warther. Mr. Warther manufactured over 11,000 "Commando Knives" for combat soldiers. Today, the Warther Museum in Sugarcreek, Ohio, is a local tourist attraction where visitors can view his intricate carvings.

So what had become of Augustus Vignos? After selling Novelty Cutlery to Dr. Carnes, he turned his interests to a new acquisition, The American Mine Door Company. Located in Canton, the company manufactured automatic doors which reduced the risk of explosions in the mining industry. Because of their safety and economy, the doors were endorsed by state mine inspectors, the United Mine Workers of America, mine engineers, operators and superintendents. The automatic doors also eliminated the need for trappers -small boys who had previously performed the dangerous job of opening and closing the shaft doors. Not only did this save the money for the mining companies, it also eliminated a portion of the child labor force in this country. Although the company was not financially successful at first, it eventually brought Augustus substantial wealth.

visit the land of his ancestry. Phoebe became active in local religious and social organizations. A local suffragette, she took their two daughters with her when she registered to vote, and this event was printed in the newspaper! Augustus was active in the local Knights of Columbus chapter and was a founding member of St. John the Baptist Catholic Church, now listed on the National Register of Historic Places. Because of his honorable military record, he served as Grand Marshall of the annual Decoration Day (now known as Memorial Day) Parade in Canton.

He retired from active participation in his business ventures in 1916, leaving his sons in charge of operations. He began spending the winter months in the warmer climate of Los Angeles. Phoebe died there

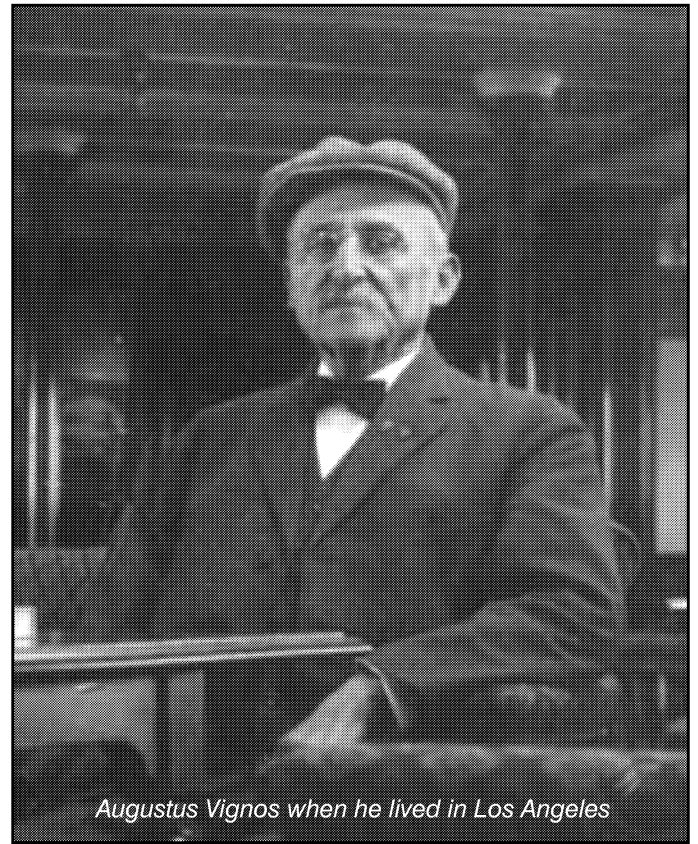

*Augustus Vignos when he lived in Los Angeles*

Catholic parish in Canton for Italian immigrants and to start programs for Catholic children who could not attend the parochial schools; in Canton and in Southern California. These Catechism classes (or CCD, as they are sometimes called) are in existence today throughout the country. The American Mine Door company is still in operation and was still owned and operated by members of the Vignos family until last year.

A note from the author:

Augustus Vignos is remembered as an important figure in local history. His son, Alfred, was my great-grandfather. Although the family fortune is long gone, our name is still recognized by many people in this area. I am proud to be a descendant of such a prestigious history.

I must acknowledge the extensive genealogical research conducted by my great uncle Charles Vignos and my brother, Timothy Vignos. This story could not have been written without the historical information provided as a result of their efforts. I also want to thank my late father, Michael Vignos, for his pride in our ancestral background. One of the highlights of my father's life was traveling to Chevannes-les-Grande and discovering long-lost French "cousins" who welcomed this stranger from America with open arms. Five generations and the expanse of an ocean could not sever the family ties!

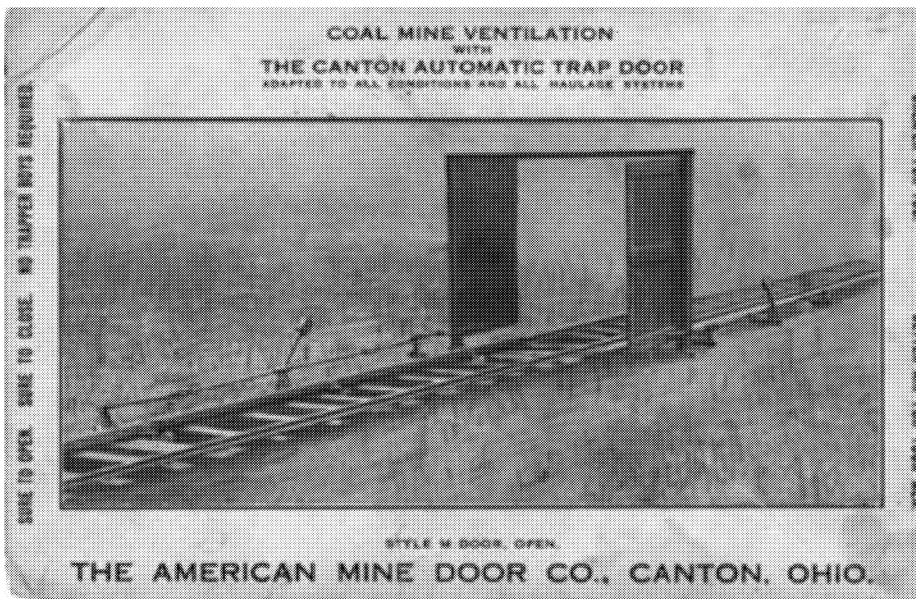

*Automatic Mine Doors*

Augustus Vignos earned a reputation as a progressive, enterprising businessman. Among Canton's industrial leaders, he also acquired a great deal of real estate in the area. His fortune made it possible for him and Phoebe to travel extensively and spend time with personal hobbies and interests, among them the breeding of specialized poultry breeds. He had the honor of serving as a juror at the 1900 Paris Exhibition Cutlery Awards, a trip which allowed him to

in 1906 and in 1925 Augustus suffered a stroke which left him bedridden. He died peacefully in his sleep a few months later, at the age of 88. His daughters were at his bedside, and they had his body brought to Canton for burial.

His influence on the city did not end with his death. His daughter was a very devoted Catholic and very charitable. Part of Augustus' estate was used to establish a

## THE THEME OF A SHOW ibdennis

Since our first Oregon Knife Show, we have stressed that our goal is to make a Show where everyone has a great time. We try year after year. Some small secrets toward this goal are making sure that everyone who works the Show have an up attitude. A pre Show huddle with security and workers stresses the no-hassle approach, and we explain what our goals are in making the Show happen. We even insist that the people who work for the Convention Center have an attitude that is compatible with our Show philosophy.

They say that a diplomat is a person who can tell someone to go to hell in such a way that the person will enjoy the trip. We recently went to a gun show after which we again claimed this would be the last show of theirs we would ever attend. To give them their due, we have addressed every negative aspect of their show in an attempt to make the Oregon Knife Show the best ever. You would think that you would build on a shows attributes and not their negatives.

Usually at these shows a table is set up to check firearms which are taken into the show. If you don't go to the check in table, you might be asked, "Do you have any firearms?" However on this occasion no question was asked, but there was a request to search my fanny pack without explanation. After the search I asked why Elayne's purse (same size as my pack) was not

searched. Thus intimidated he requested a look see into her purse. However, at no time did the person look into the part of the pack where a gun is usually located. And what was in the fanny pack you might ask? Oregon Knife Show flyers.

There were several issues here that are relevant to our Show. By the time I entered this gun show I was upset. After a long drive I had been looking forward to an up experience, and right out of the starting gate I faced a lesson in poor customer relations and the results of paranoia in a delicate situation. The day was destroyed for me, and the dollars spent reflected this. Zero dollars of mine were left here even though there were many opportunities for purchase.

The gun show was other than a fun experience for table holders and even for the people that were there. The theme of this "gun" show was purses, luggage, jewelry, flashlights, gadgets, lamps, wall posters and other non firearms related items. A sad parody on the name of the event. It is no wonder that knife shows are gaining in popularity these days. We of the Oregon Knife Club are dedicated to make our Show an all knife show and the best in the world. We are truly committed toward that goal.

So how can each of you help keep this spark of fire going? By having an up attitude. By saying "have a nice day" and really meaning it. Greet your customers and friends with a better than ever brightness in your eyes and a smile that will

make the worst the best. Be a grump and watch all those around you turn into grumps. Grump is as grump does.

Likewise we ask that the tables holder wares reflect the theme of our Show. This is a knife show, and your tables should reflect that. A few other items that are not knife related can be on a table, but we ask that you evidence good taste and observe our goals.

Our goals at the Oregon Knife Show are to provide a great atmosphere and a delightful meeting place. It better be fun. If your only goals are to sell and make money, then you must make the best of the atmosphere we provide. If you are not successful in your sales, then the burden of blame rests on you. We bring in the people that are knife interested. We advertise and promote and we set the stage for the play. If the play stinks, then maybe some of the blame can be laid on the players.

By the way... neither the economy nor the tragedy negatively affected our last Show. We worked hard to reverse the negative trend. We are doing the same for the 2003 Show. Come see us and see how we do it. Our Show is affordable and encourages visitors to stay and enjoy. And they do.

This is the best show in the world, and you can help be a part of the action. See you at the 2003 Oregon Knife Show.

## Mike & Barb's Corner

Well here it is the first of October, 2002, summer is gone and fall is in the air. This can be a great time of the year for collecting things. The flea markets start up around Eugene. Seems like we have about three right in the area almost every weekend. If you start right away, you can have some good luck finding knives. There is always Ebay. You will have to excuse me; I just put on another pair of glasses. I now have one pair of glasses for reading and wearing outside, and another pair of glasses for the computer. It works real good.

Right now I am getting ready for the Northwest Knife Collectors show in Puyallup, Washington. You probably have never heard of that city. It is just outside Tacoma. They have one of the largest gun shows between the two states of Oregon and Washington. The Northwest Knife Collectors have space right in and beside this show. They boast that 10,000 people come to this show.. Most knife collectors like guns so you can look at both. Barb and I have two tables at this show with one trade and one display. We both look forward to attending this show Oct 5 and Oct 6, 2002.

Speaking of shows, the Oregon Knife Collector's Mini Winter show is right on time, and I am taking table orders as we speak. I think we have about 25 table reservations now. We expect about 90 to 100 tables of knives. That's about all we can handle at this time. Last year we had a full house

with some people still wanting to get a table. I know I sound like a car salesmen, but it is the truth.

As you know, if you are a member of the Oregon Knife Collectors, the table is free. The Club pays for the tables which are rented from the fairgrounds. You cannot beat that, it's free if you are a paid up member. Barb just said she would not buy a used car from me, can you believe that? I forgot to mention that Barb Kyle is setting up her mini knife display at the Northwest Knife Collectors show in Puyallup. I will have the trade table.

The Oregon Knife Collectors Mini Christmas show is Saturday Dec 14, 2002. Table set up at 7AM open to public at 8AM, show closes at 4PM. The Christmas pot luck is at 5PM in the same building. The Club buys honey ham, smoked turkey and salmon. The rest of us bring all them great desserts. It's a great dinner. Last but not least please bring a gift for a child unwrapped and new for up to age 12 yrs. This is for Toys for Tots put on by the United States Marines and the fire department. We surprize them every year with the amount of gifts for the kids.

Looks like to me all you have to do is get yourself to the Christmas mini show, bring some food for the pot luck, bring a gift for the kids (two would be OK). Bring some knives too. Above all come with a good time in

mind. Get around, meet some people and talk knives.

Now for the good part. You can call me or Barb at (541)998-5729 or a-doxiex2@att.net. Remember that tables are first come first serve. That means you get at the door first, and you get to pick the table. Sharing tables is OK at this Show but not at the April Show. Things got a little tight last year so I would not waste any time on it.

Take care and we will see you soon. December 14, 2002, Mini Winter Christmas Show.

Mike & Barb Kyle

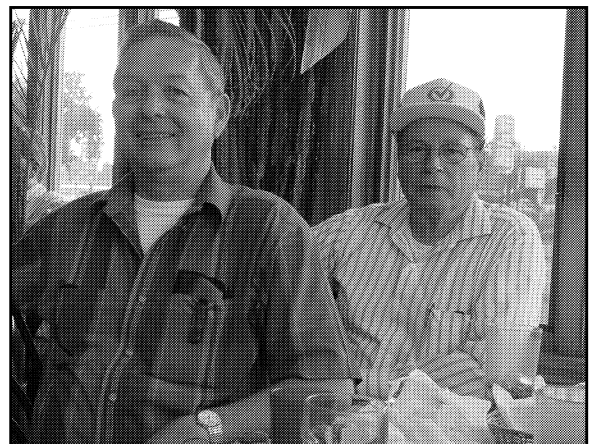

Mike Kyle & Jimmy Brown





# OREGON KNIFE COLLECTORS ASSOCIATION

BOX 2091 • EUGENE, OR 97402

MEMBERSHIP APPLICATION AND SHOW TABLE CONTRACT

**\*PLEASE RETURN THIS ENTIRE PAGE or a photocopy. DO NOT CUT IT UP!\***

Name(s) \_\_\_\_\_

Mailing Address \_\_\_\_\_

City \_\_\_\_\_ State \_\_\_\_\_ Zip \_\_\_\_\_

Phone: Eve ( \_\_\_\_\_ ) \_\_\_\_\_ Day ( \_\_\_\_\_ ) \_\_\_\_\_ Date \_\_\_\_\_

Collector \_\_\_\_\_ Knifemaker \_\_\_\_\_ Dealer \_\_\_\_\_ Mfr./Distrib. \_\_\_\_\_ Other \_\_\_\_\_

OKCA membership includes newsletter, dinner/swap meetings, free admission to OKCA shows, free OKCA Winter show tables, right to buy OKCA club knife.

\_\_\_ Start/ \_\_\_ Renew my/our OKCA membership (\$20 individual/\$23 family) \$ \_\_\_\_\_

## 2003 28TH ANNUAL OREGON KNIFE SHOW • APRIL 12-13, 2003 470 — 8'x30" TABLES

Exhibit Hall, Lane County Convention Center and Fairgrounds, 796 West 13th Ave., Eugene, Oregon.  
FOR INFORMATION CONTACT SHOW CHAIRMAN: DENNIS ELLINGSEN, (541) 484-5564

**AUTOMATIC RESERVATIONS:** If you had a table at the 2002 Show, you have an automatic reservation for the same table in 2003, but THIS RESERVATION EXPIRES DECEMBER 15, 2002. You may still apply for a table after this date, but we cannot guarantee a table after December 15. NO RESERVATIONS HONORED OR APPLICATIONS ACCEPTED WITHOUT FULL PAYMENT! Note to NEW exhibitors: your table(s) will be assigned after 12/15/02.

**ALL TABLE HOLDERS AND VISITORS** agree to abide by the OKCA show rules, and to hold the OKCA, its officers, and the Lane County Fair Board harmless for any accident, loss, damage, theft, or injury.

**ANY QUESTION OR DISPUTE** arising during the show shall be resolved by the Show Chairman, whose decision shall be final.

**THIS IS A KNIFE SHOW.** All tables must be predominantly knives or knife related items (e.g. swords, axes, edged tools, edged weapons, knife books, knifemaking supplies). If in doubt, check with the Show Chairman ahead of time. The OKCA reserves the right to bar any item from display or sale. No firearms made after 1898 may be sold or shown at this show.

**ALL EXHIBITORS are required to keep their tables set up throughout the public hours of the Show: 9 AM Saturday to 3 PM Sunday. ANY EXHIBITOR WHO LEAVES BEFORE 3 PM SUNDAY FORFEITS HIS FUTURE RESERVATIONS AND WILL BE DENIED TABLES AT FUTURE OREGON KNIFE SHOWS.**

**DISPLAY TABLES** will be around the perimeter of the room. All displays are eligible for display awards, which are handmade knives donated by members and supporters of OKCA. Display judging will be by rules established by OKCA. Special category awards may also be offered. **NOTHING MAY BE SOLD FROM DISPLAY TABLES.**

**SALE/TRADE TABLES** Sharing of tables will not be allowed. Exhibitors must comply with all applicable local, state, and federal laws. Oregon has NO SALES TAX.

**BADGES:** Each table holder is entitled to one additional show badge.

**KNIFEMAKERS** who are present and are table holders at this show may enter knives in the knifemaking award competition.

**FOR MORE INFORMATION** on categories and judging criteria in the display and handmade knife competitions, contact the Show Chairman.

**SECURITY** will be provided by OKCA from 10AM Friday

until 4 PM Sunday. However, exhibitors are responsible for watching their own tables. Neither the OKCA nor the Lane County Fair Board will be responsible for any loss, theft, damage, or injury of any kind.

**CITY AND COUNTY REGULATIONS** require that there be:

- No Smoking within the Exhibit Hall at any time;
- No alcoholic beverages consumed within the Exhibit Hall during the public hours of the show;
- No loaded firearms worn or displayed at the show;
- No swords or knives brandished or displayed in a provocative manner.

Violators of these safety rules will be asked to leave.

**NOTE ON SWITCHBLADES AND DAGGERS:** In Oregon it is legal to make, sell, buy, or own switchblade knives. However, it is *ILLEGAL* to carry a switchblade knife, a gravity knife, a dagger, or a dirk concealed on one's person, or for a convicted felon to possess a switchblade or gravity knife. Most other states have banned switchblade knives. Under federal law, it is *ILLEGAL* to mail, carry, or ship a switchblade or gravity knife across state lines.

### SHOW SCHEDULE

**Friday, April 11, 2003. 10am - 8pm** set-up; open **ONLY** to table-holders and members of OKCA.

**Saturday, April 12, 2003. 7am-9am** set-up. **9am-6pm** open to public. **6 pm** no-host bar, **7pm** food, awards, entertainment. Tickets Required.

**Sunday, April 13, 2003 8am-9am** set-up. **9am-3pm** open to public.

**Tables that are cancelled will revert back to the OKCA. Subcontracting tables is not permitted.**

**EXHIBITOR CONTRACT:** PLEASE ENCLOSE FULL PAYMENT WITH THIS FORM. Full refund granted if reservation canceled by February 15, 2003; for later cancellation, refund will be granted only if your table is rented to someone else. **DON'T GET LEFT OUT!!! MAIL THIS PAGE AND YOUR CHECK TODAY. A signature is required.**

Type of knives on your tables \_\_\_\_\_

Name for second badge \_\_\_\_\_ (two badges per table holder)

\_\_\_ **Club Dues (Total from above)** ..... \$ \_\_\_\_\_

\_\_\_ **SATURDAY NIGHT SOCIAL TICKETS @ \$12 each:** ..... \$ \_\_\_\_\_

\_\_\_ **Sale/Trade table(s) @ \$95 each (members only)** ..... \$ \_\_\_\_\_

\_\_\_ **Collector Display table(s) free with sale table:** ..... \$ \_\_\_\_\_

TOTAL ENCLOSED (make check payable to O.K.C.A.) ..... \$ \_\_\_\_\_

I have read and agree to abide by the OKCA show rules as set forth in this contract, and to hold the OKCA, its officers, and the Lane County Fair Board harmless for any accident, damage, loss, theft, or injury.

Signature \_\_\_\_\_ Date \_\_\_\_\_

**\* PLEASE RETURN THIS ENTIRE PAGE or a photocopy. DO NOT CUT IT UP!\***

www.oregonknifeclub.org

## Oregon Knife Collectors 2003 Club Knife

This year we are offering a Butch Vallotton folding pocket knife for the members of the OKCA. This is an original design and it will have honey coloured bone handles; a hollow ground blade made from 440C; it will have a signature forged over liner lock; titanium liners (anodized) and thumb stud; the handle is 3-1/2" (8.9 cm), the blade is 2-1/16" (6.8 cm) and overall is 6-1/8" (15.5 cm) . The knives will be serial numbered and will have the OKCA logo etched in the blade. Only 50 knives will be made for sale to our Club members. One knife per person at this first offering.

The special price for this knife is \$200.00 each.

Name \_\_\_\_\_

Address \_\_\_\_\_

City \_\_\_\_\_ State \_\_\_\_\_ Zip \_\_\_\_\_

Quantity \_\_\_\_\_ Amount enclosed \_\_\_\_\_

Please add \$8 for shipping if you will be unable to pick this knife up at the Show on April 12-13, 2003.





# OKCA Free Classified Ads

Free classified ads will run up to three issues and then be dropped. Available only to paid members. Write your ad on anything you have handy (except banana skins) and mail to the **OKCA, PO Box 2091, Eugene OR 97402**. The number and size of ads submitted by a single member will be accepted or excepted dependent on available space and the mood of the editors.

**For Sale** - Overholser lock blade folding knife for sale. \$250. 3" blade, brass liners and bolsters, stag handle slabs. Marked #1 1987. (541)689-8098 ask for Wayne. e-mail wgoddard44@earthlink.net S

**For Sale** - Six custom Goddard folders made in the mid 70's for sale individually.(541)689-8098 ask for Wayne. e-mail wgoddard44@earthlink.net S

**For Sale** - New Dayton motors \$100. 1-1/2 hp 3450 rpm 115/230 56c face frame. Three at this price. 4x60 abrasive belts 80-120-320 \$2.00ea. CPM-S 30v steel 3/16x1-1/2 \$16.50 foot. Call John @ Tru-Grit (800)532-3336 S

**For Sale** - 6" x 12" Covel Surface grinder, 1/2 hp 110v, includes diamond dresser and assorted grinding wheels. \$2,000.00, contact Jim Gillespey Vancouver, WA (360)576-9114 or jmgillespey1@attbi.com S

**Wanted** - Commemorative Blue Grass Series-Belknap Hardware Company. Need mint condition numbers 1, 2, 7, 9, and 10. Please call Mike at 541-336-2107 or email at Mtyler77@webtv.net S

**Wanted** - John Ek knives marked Hamden,Conn and Miami,FL. Also original sheaths, catalogs and advertising items. Contact Richard at: (619)437-0564 or at: kaasu111@aol.com S

**For Sale** - Blade blanks. Also some A2, D2 and O1. Contact Gene Martin at (541)846-6755 or email me: bladesmith@customknife.com S

**For Sale** - Complete engraving outfit. Large GRS ball w/accessories kit (1 piece missing), Gravermiester compressor, foot switch, one hand piece, assorted cutters, engraving book, GRS sharpener with diamond and stone wheels, tool sharpener jig. Won't break up the set. Firm \$1,800. Contact Bill Herndon (661)269-5860 bhernsons1@aol.com S

**For Sale** - Natural finish Oak display box lined with black velvet 13-1/4 x 3-3/8 id dimensions 1-1/8 deep \$50 + s/h Craig Morgan (541)345-0152 S

**Wanted** - M..W. Seguine knives, Juneau, Alaska maker. Will consider most any condition. Contact Jack (805)489-8702 or email jh5jh@aol.com S

**Wanted** - email pictures of unusual Schrade Cut Co or Schrade Walden tang markings. Please send picture of knife, closeup of tang marking, any interesting bolster or emblem markings wanted also, with permission to use picture. Send to Beaker@sunset.net with my thanks ahead of time. Working on article for Knewsletter. M

**For Sale** - Marzitelli Prowler. New from Columbia River Knife and Tool (CRKT) "The Prowler" designed by Canadian custom knife maker Peter Marzitelli. This is one heavy duty locking liner folder that's built for serious work. One of the finest features is the unique opening system called "The Groove." Super easy blade deployment with very little effort. (M.S.R.P. \$59.99) For more info contact a dealer near you or call Peter Marzitelli (604)532-8899 M

**Scrimshaw** by De. Single or full color. Subject of your choice. Multi-medium artist. Contact for more information at De McQuestion (541)266-9339 or d.mcquestion@juno.com M

**Wanted** - OKCA '98 Wayne Goddard Spyderco Club Knife. If interested in selling, please contact Ron Brown at mrtoad@internetcds.com. M

**Stabilize** - Make wood harder-fast. Do it yourself at home. Antler, wood, bone. Positive process, no special equipment. Approximately \$2 per piece. Hiltary Recon-if we can do stone, you can easily do the above. Call (800) 872-5263 or SASE: Hiltary Box P Scottsdale AZ 85252 A

**Wanted** - Knuckle knives, especially with military significance. Gerber Mark II combat/survival knives: interested in early and unusual pieces and related items and histories. Canted blades, colored handles, dive knives, etc. If you carried a MKII, please let me know. Also Kukri's, Rnadall's, F-S Commando, U S Military knives and nice old fighting knives in general. Phil Bailey POB 13000-A Portland OR 97213-0017 (503)281-6864 email pbailey@europa.com A

**For Sale** - Pierce-Arrow throwing knives - 1 for \$60.00, 3 for \$160.00 or 5 for \$250.00. Made from 5160 high carbon spring steel. Measure 13"x1-5/8"x1/4" and weigh 13oz. 1 oz per inch. Cloth carrying pouch \$10.00. S/H \$6.00 for one and \$3.00 for each additional. Bob Patrick 816 Pearce Portal Dr Blaine WA 98230 (604)538-6214 or bob@knivesonnet.com M

**For Sale** - Miniature knife collection, all or part. For details call Mike Allen (903)489-1026 or email whiskersknives@aol.com M

**Your Knife Questions ANSWERED ON-LINE.** Bernard Levine, author of Levine's Guide to Knives and Their Values, will answer your knife questions on the Internet. Is that knife on eBay real or fake? Is the knife you're thinking of buying authentic? What kind of knife do you have, and what is it worth? What is the value of your collection, for insurance or tax purposes? Instant payment by Visa, MasterCard, or PayPal. Go to: <http://pweb.netcom.com/~brlevine/apprk.htm> or to [www.knife-expert.com](http://www.knife-expert.com)

**"Randall Fighting Knives In Wartime"** by Robert E. Hunt. A colorful and interesting guide to Randall knives spanning the three major conflicts (WWII-Korean-Vietnam). Call (270)443-0121 Visa/MC (800)788-3350

**"Knife Talk"** by Ed Fowler. 60 past *Blade Magazine* articles combined w/the author's updates and 200 photos. Take a trip with the father of "Multiple Quench" \$14.95 plus \$3.20 S&H - Ed Fowler - Willow Bow Ranch P O Box 1519 Riverton WY 82501 - (307)856-9815

**"Bayonets, Knives & Scabbards"** Thought to be the most important paper ever written of U. S. edged weapons by the U. S. Government. Available for the first time to the general public in one volume, covers U. S. Army edged weapons from 1917 through the end of World War II. Soft cover, 80 pages filled with facts. Even the advanced collector will find "new" material between these covers. \$15.95 + \$3 priority postage. Frank Trzaska - Knife Books P O Box 5866 - Deptford NJ 08096

**"The Wonder of Knifemaking"** by Wayne Goddard is soft cover 8 1/2 x 11, 160 pages, 16 page color gallery. \$19.95 + \$3.05 (\$23.00) shipping in U.S. Send a check or money order to: Goddard's, 473 Durham Ave, Eugene, OR 97404. Or call (541)689-8098 to order using Visa, MC or Discover cards.

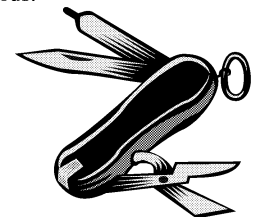

*The views and opinions implied or expressed herein by authors and advertisers are not necessarily those of the Oregon Knife Collectors Association, its editors, or its officers; and no responsibility for such views will be assumed. The OKCA, its officers and its editors assume no responsibility for claims of advertisers for the quality of goods and services the advertiser provides. The act of mailing or delivering a manuscript or advertisement shall constitute an express warranty on the part of the contributor that the material is original and in no way an infringement upon the rights of others. The act of mailing or delivering a letter or question to the editor shall constitute permission to publish the letter or portion thereof unless the Oregon Knife Collectors Association is informed otherwise in that letter.*



**The Knewsletter**  
 Oregon Knife Collectors Association  
 PO Box 2091  
 Eugene, OR 97402

First Class Mail  
 U.S. Postage  
**PAID**  
 Eugene, OR  
 Permit No. 388

## Events Calendar October 2002

----- <b>October</b> -----		----- <b>March 2003</b> -----	
Oct	05-06	-	NWKC Washington Show -Puyallup WA (KW-B)
Oct	11-12	-	Northern Lakes Show -Edgerton WI (KW-B-KI)
Oct	19-20	-	Arizona Show -Mesa AZ (KW-KI-B)
Oct	19-20	-	Munich Knife Show -Germany (B)
Oct	25-27	-	Ohio Fall Show -(KW-B)
Oct	26-27	-	ABS Moran Hammer-In -Old Washington AR (KW-B)
Oct	26-27	-	Oberhausen Knife Show -Germany (B)
----- <b>November</b> -----		Mar	08-09 - Bunker Hill Knife Show -Godfrey IL (KW)
Nov	01-02	-	New York Custom Show-NY (KW-B)
Nov	02-03	-	Mt Vernon Show -Mt Vernon IL (KW-B)
Nov	08-10	-	Ft Myers Knife Show -Florida (KW-B-KI)
Nov	22-23	-	Greater Ohio Valley Show -Cambridge OH (KW-B-KI)
----- <b>December</b> -----		Mar	14-15 - Mason Dixon Show Sharpsburg MD (KW)
Dec	05-07	-	Greatest Knife Show - Pigeon Forge TN (KW-B-KI)
Dec	14-15	-	Heart of America in St Charles MO (KW-B-KI)
Dec	14-14	-	<b>Oregon Winter Mini Show - Eugene OR</b>
----- <b>January 2003</b> -----		Mar	14-16 - NKCA Ohio Spring Show -(KW)
Jan	17-19	-	Las Vegas Classic Knife Show (B)
Jan	24-26	-	Chattanooga Knife Show -TN (KW-B-KI)
Jan	24-26	-	Wolverine Knife Show -Novi MI (KW-B-KI)
Jan	31-02	-	Gator Cutlery Show -Lakeland FL (KW-B)
Jan	31-02	-	American Bladesmith Expo -Reno NV (KW-B-KI)
----- <b>February 2003</b> -----		Apr	04-06 - Shenandoah Valley Knife -Harrisonburg VA (KI)
Feb	08-09	-	Arkansas Custom Show -Little Rock (KI)
Feb	21-23	-	Knife Expo 03 Buena Park -CA (KW-B)
Feb	22-23	-	Atlanta Knife Show -GA (KW-B)
		Apr	12-13 - <b>Oregon Knife Collectors Show -Eugene OR (KW-KI)</b>

### DINNER MEETING



**Thursday Evening**  
 October 10, 2002

**G Willickers**  
 440 Coburg Road  
 Eugene Oregon

**6:00 PM Dinner**  
**7:00 PM Meeting**

*Show-N-Tell —  
 Bring a special knife!*

Contact Dennis or Elayne (541) 484-5564 for additional information on OKCA events. For non-OKCA events, contact the sponsoring organization.  
 Additional info = (B)lade Mag. -(KW) Knife World - (KI) Knives Illustrated

