



**KNEWSLETTER
IN A KNUTSHELL**



It is all about the **OKCA Show**

Our *international* membership is happily involved with "Anything that goes 'cut'!"

May 2017

2017 Oregon Show

ibdennis

We made it happen. It was like we were the conductors of the orchestra, and the music came out sweet and wonderful. It feels good to expend the efforts and see the rewards first hand. Although we have made the same things happen over and over throughout the years, the music this year seemed to outdistance all efforts before. We cannot describe or explain it, but we just knew it was good. It felt good and flowed without mishap that we knew about. Yes, there was one blatant gaffe that had to do with the food concession; but it was so out of our hands that nothing could be done to fix that which was broken. But aside from that.....



Everything was just great. We had nurses on duty for cuts and bruises, and they played the role of the Maytag repair people. Unlike last year, there was no blood draw that called for special attention. Our gate that we could account for was up from last year. Our fund raiser for the Silent Auction was up also which told us we are on track.

Photography at the Show....

I put the recording of our Show to our Show Photographer **George Filgate**. This year I left the camera at home. This alone freed me up to run the Show with a little more efficiency. George is an excellent photographer and documents our Show with the precision of a brain surgeon. I wish I could publish all the pictures taken, but the pick of the crop will have to do because of space limitations. Our picture library goes back for years and is a great historical collection of who, where and what.



Demonstrations....

I managed to pop in for a few minutes to each of the demonstrations and seminars and was pleasantly pleased with the turnouts at each event. It was the most attended per session of any year I can recall. By popular demand we had two seminars that were back to back, with exhibitions of a different nature at the same time. The session by **Dan Westlind** on making knife handles exceeded the expectation of attendance. The same goes for **Dale Larson** and his presentation on his Bowie knife. I asked a few who attended their reaction, and several came back with the same answers, "...the best educational seminar they have attended in years." Again a very large crowd.



Continued on page 2

The Show's success....

I had to ask several people to what they attributed the up attitude and glowing happy place. Of the numerous comments, the one that rang true was the economy. I heard from many that the Show was the best financially they had experienced in awhile. I am sure that not all had such success, but I heard slight few of negative comments. Sales are something for which we cannot take credit, but we do attempt to bring the crowds in with our due diligence on the advertising. Then again most of the sales come from our members who are dedicated to their interest in knives and their collections.

We had a total of ten tables depart the Show early on Sunday. These were without notice. We understand when circumstances require an early departure, but it is necessary that we be advised. The table-holders have committed to the hours of attendance, and an early departure is not acceptable. For this reason those individuals will not have tables at future Shows. The person who departed his five tables got my attention when he took the tablecloths, too, which was not his to take.

I might also mention that our policy to not take memberships or renewals on Friday worked out to eliminate labor and confusion during set up day.

It is a big Show....

How big? Humongous say many. I for one see less than one percent of the Show, and my rewards of finds come from those who know my interests and point out treasures to me. In fact that was the truth of all we purchased this year. Many years ago someone pointed out time spent per table to see the whole Show. Of course not with depth or special pursuits. If you were the general public and could only use the public hours, one would only get to spend



2.43 minutes per table to see the whole Show. If one were a member and took advantage of the members' day, then you would be getting a whopping 3.72 minutes per table. Heaven forbid you engage in conversation, as that would rob precious minutes from the next table. Then there are the demonstrations that you might want to see, thus taking away some more table looking time. The answer: keep coming back each year to get a better scope of the event. The other answer is to hone your interests and survey those tables that catch your fancy. If you are a collector of certain makers, you can save time by looking at our roster that we publish on our website; or

you can get site maps at the Show to track down your maker. We claim to be the biggest cutlery Show east and west of the Mississippi River with the notation that this is a not-for-profit organization. There is no other organization that presents an event of this description anywhere else in the world.

Just a point of trivia....

We have row letters at all end tables. These serve to guide you to where you want to go and help you to locate your location. The main reason for these letters is far more important than that. If a situation calls for the aid of medical assistance, knowing the exact location is time critical. In a Show this size, location is paramount to get help. We have not had a major issue, but our minor issues have made us aware that it is a necessity. We should mention that our Show Facilitators helped the Show with up attitudes and help to our guests. This year we had **Dave Jones** handle this, in addition to providing Show security during the night. Dave is bonded and licensed for this task, so we are grateful for his help.

Custom Knife Competition....

This has always been a popular event, and there was some fine tuning of the event for this year. We started the acceptance of knives for judging earlier this year so we could get the knives judged and returned well before the early evening. Some very special knives were submitted this year, and the categories of scrimshaw and miniature came back to life with entries. We also increased our helper staff to make this event move more smoothly. **John Priest, Edward Davis, Ray Ellingsen, Grace Mikolyski, Clay Stevens, and Lisa Wages** are to be thanked for their assistance. The judges are also to be thanked, however they request anonymity. Just beware that they are the best of the best in their knowledge of "things that go cut." The list of the winners are showcased in this issue.



This was the winning paring knife by Theo Eichorn.

Paring knives....

The making of award knives from the blanks of steel which are provided has evolved over the years to what it is today. We never have a shortage of knifemakers who want to take on the challenge. Doing the paring knife blank seemed like a blasé endeavor at first. **Gene Martin** is the coordinator of this event and informed me that this pattern was a very difficult task. I soon learned the complexity of problems that the makers faced. Working with this thin a blade could cause warping if not careful; much less figuring out a uniqueness for this common kitchen item. What a surprise to see the beauty and original creativity of each of these knives. The judges were blown away with the artistic approaches but agreed that the simplistic, utilitarian approach by **Theo Eichorn** won their votes.

The Seek-Re-Tary Report

elayne

The last *Knewsletter* for the 2017 Show Year, but not the last for the calendar year. We will resume publication in September, 2017. I always review the previous year's Show *Knewsletter* before I compose my article for the Show which has just finished. This year, after review of the 2016 article, I was challenged to improve on what I wrote for the 2016 Show. However the 2017 Show was even better in so many ways that it must be acknowledged as a SUCCESS that was enjoyed by the many who were able to attend: the table-holders, the displayers, the handmade knife competitors, the demonstrators/seminar leaders, the OKCA Staff, the visitors and the OKCA Officers. We need to applaud ourselves for another successful event. I thank all of the individuals who were kind enough to stop at the Club Table to acknowledge the quality of the event and their enjoyment of the event. This is the necessary fuel for the Officers to continue to expel the energy to do it again.



We did make a few changes this year. We did not take any new or renewal memberships on Friday, set up day. We announced this policy in our *Knewsletters* (as well as the April issue which was mailed to past visitors and lapsed members) and also posted the information on our Facebook site and our website. We did have a number of individuals who were very disappointed that we had discontinued this policy. However it reduced our confusion factor



and also our need for additional help. It will continue. A number of individuals had contacted me prior to Friday of Showtime and cried "UNCLE." Special arrangements were made for them to enter on Friday with the table-holders and members. I required they advise me the names of the members to be added, have an application filled out and correct change. I would laminate their cards before Friday and have them on will call at the Club Table. Exceptions can be made if arranged ahead of schedule.

One of the other major changes to our past policies was the earlier start of the handmade knife competition. We also added help to that event to handle the rush. My reports stated that it was much more organized and went more smoothly. Thank you **John Priest, Edward Davis, Raymond Ellingsen, Grace Mikolyski, Clay Stephens and Lisa Wages.**

My list of thank you's always start at the crew that helps set up Friday morning. They set up the schedule signs and map signs as well as the signs on the doors; put the aisle signs in place; place table number sheets and information sheets on the tables; set up the literature table and the table with the table-holder's packets. The same crew has volunteered for the job for the past seventeen years so very



little direction is necessary. Thank you for your help. It is very much appreciated.

Thank you to **Spyderco** who again donated a gift (a ceramic stone) to each of our table-holders. Thank you **Roy Humenick** who coordinated the selection of the 2017 Club Knife. All sold. It is a money making project that helps to offset the cost of our event so we are able to keep the table fees affordable.

Thank you to **Barbara Kyle and Sue Myers** who distributed the table-holder packets. Thank you **Cindy Bristol and Dee Weiler** for greeting our admission visitors to the Show. It is not an easy task to smile for that many hours and still make change.

One of the concerns we faced was the coordination of our Facilitators for the 2017 Show. Our previous arrangements were not available. **Dave Jones** who had worked with us before volunteered to coordinate the Facilitators. Thank you very much for your help, Dave. It was well done. Thank you to the Facilitators: **Scottie Ankrom, Jessica Dance, Steve Gilmore, Charles Jones, David Jones, Melisa Jones, Lisa McCranie, Al Stromme and Darrel Wilson** for the acceptance of the challenging job to greet our visitors pleasantly, answer their many questions, then guide them to the exits (not entrances) and keep smiling as the days wore on. We again had our ace in the hole with the presence of **Tim Cooper** to help with the coordination as well as our rabbit's foot **Ana Cooper** who warded off any injuries to our visitors. No major bloodletting this year.

As always a very special thank you to **Glenda Brown**, the coordinator of the Silent Auction. For several years she has been the behind-the-table help which is so necessary for me. She helps me to see the bright side of the day and smile when that is the only solution to a problem. Thank you **Brian Huegel** who solicited the Silent Auction and Door Prize items from vendors across the country.

Continued on page 6

Handmade Knife Competition

There were 75 entries into the categories for competition by custom makers.

Plaques were awarded to the makers and were engraved by **Chuck Richards**.

Event Coordinator **John Priest** | Photography by **George Filgate**

Art Knife

Mike Tyre -
Wickenburg AZ



Hand Forged

Ian Rogers -
Vancouver WA



Bowie

Jeff Murison -
North Plains OR

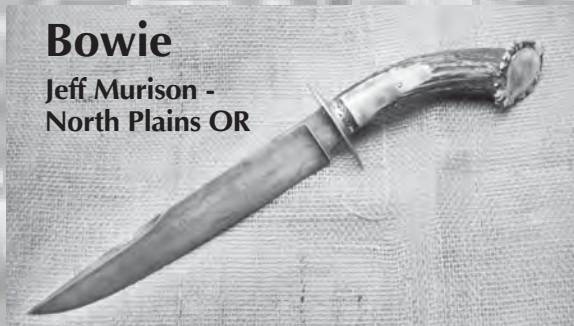

Hunter/Utility

Michael Faber -
Reno NV



Damascus

Salem Straub -
Tonasket WA

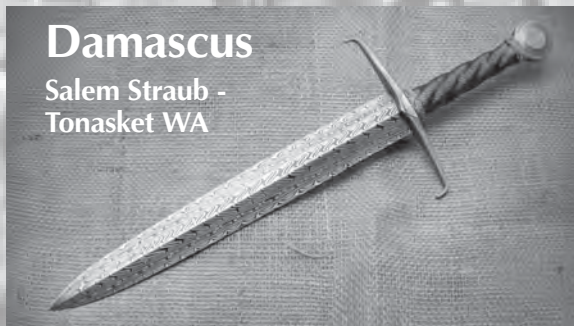

New Maker

Andrea Lisch -
Yelm WA



Fighting

Ben Tendick -
Eugene OR



Scrimshaw

Carmen Taylor -
North Fork CA

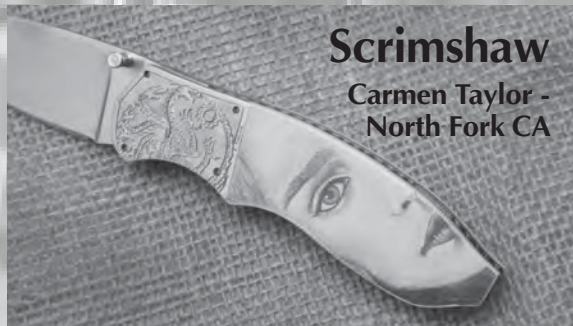

Folding

Bill Burke -
Boise ID



Best in Show

Salem Straub -
Tonasket WA



Handmade Knife Competition

Paring Award Knife

Theo Eichorn -
Grants Pass OR



The paring knives which had been completed by the custom knifemakers and were to be presented for the best displays were judged. The knife created by Theo Eichorn was judged to be the best of these.

Miniature Knife

Craig Morgan -
Eugene OR

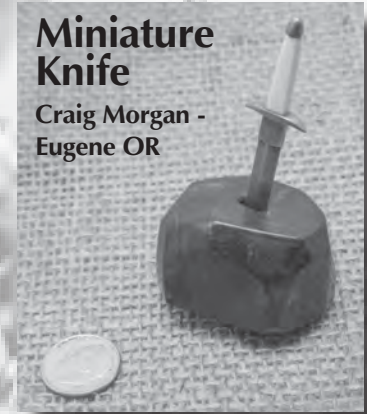

Contributions

Many companies and individuals contribute knife-related items and financial support to the Oregon Knife Collectors Association Annual Show.

The Silent auction and door prize items are displayed prominently during the course of the Show. Door prizes are awarded by drawing to the public who have paid Show admission.

The contributors to our organization are listed on our web page <http://www.oregonknifeclub.org>

The following is a list of the people and companies who have contributed to the OKCA:

Al Mar Knives

Apogee Culinary Designs

Rob Bransfield

Bob Burtscher

Matt Caldwell

Charlie Campagna

CAS Iberia

Coast Cutlery

Cold Steel

Columbia River Knife & Tool

Country Knives Inc - Brian Huegel

David Kurt Handmade Knives

Epicurean

Flexcut Carving Tools

Great Eastern Cutlery

Bob Hergert - Scrimshaw

Steve Huey

Ka-Bar Knives

KAI/Kershaw

David Kurt Handmade Knives

Kyocera International

Bruce Lanham

Leatherman Tool Group

Ron Nelson

Ontario Knife Company

Oregon Leather

Ed Schempp

Jim Schick

Mike Silvey

Spyderco Knives

Wustoff Trident

Xikar

Displays at the Show

There were 18 museum quality displays at the 2017 Show. The display winners choose one of the award knives which were completed from the 2016 blanks for the 2017 Show. Awards were presented for the following displays:

Individual	Display Title	Knife Chosen
Dale Larson	Edwin Forrest Knife	Jeff Murison
Jim Pitblado	Remington Official Boy Scout Knives	John Coleman
Mike Adamson	Great Oversize And Display Knives	Jim Jordan
Phil Bailey	Battle Bowies	Blair Todd
Ted Fitzwater	World War II Military Kukris	Bernard Ortiz
Barbara Kyle	Miniature Knives	Steve Goddard
R Terry Gail	Case Stag Pocketknives	Jeremy Spake
Dave Schultz	Sunday Knives	Theo Eichorn
Lhmond Jones	Hobo Knives, Slot Knives	Brian Wages
Michael Kyle	Remington Knives 1982-2012	Gary Griffin

Thank you to all who displayed at the 2017 Show:

Mike Adamson - Phil Bailey - Jack Birky - Buck Collectors Club - Ron Carriveau - Ted Fitzwater - R Terry Gail - James Gedlick - Don Hanham - Ed Holbrook - Lhmond Jones - Barbara Kyle - Michael Kyle - Dale Larson - Mareko Maumasi - Jim Pitblado - Dave Schultz

And the Show goes on...

A few years ago Elayne and I had wanted to reduce our involvement in the Oregon Knife Collectors Organization, *Knewslettter* and Show hoping to get a younger, more innovative, individual who could transition and perpetuate the events and organization. We explained over and over again that we did not want to “retire” but wanted to see the organization grow. That did not happen so we came back to continue our work to make this organization and Show continue. We, like the marriage vow states, will continue until death do us part. Elayne and I have talents which help with the organization and realize that not many others have these talents, much less

the drive or passion to take on the job we have done for 43 years. We enjoy (if that can be said) making the event happen, and our rewards are not financial. The participation from our membership to purchase tables, write articles and help in many ways is what turns our crank. The special thank you comments we hear at the Show are special to us. Yes, we profit from the Show from one member who has gifted us year after year in ways we cannot refuse. And the special food products from around the country that we get are special. This year we received apricot, blueberry and strawberry preserves which served to enrich our thank you acknowledgments.

Special items.....

Spyderco has been gracious each year with a gift to our table- holders. This year it was a medium grit ceramic stone

that is a perfect item for hand sharpening or touching up a blade. The OKCA also likes to give out a memorabilia item of the Show. The adage is “don’t take any wooden nickels,” but everyone eagerly accepted these that were handed out. Even as **Tim Cooper** handed out chocolates to the ladies, there was always the male counterpart who held out his hand and was given a wooden nickel rather than a chocolate. Sweets for the sweet as one recalls. Of course Tootsie Pops are the hallmark of our Show, and we went through 1200 of these, plus assorted candies. Thank you to the two ladies who counted 316 licks to get to the center of the Tootsie Pop.

We hope to see you again April 6-8, 2018. 🐾

The Seek-Re-Tary Report
continued from page 3

Thank you **Grace Mikolyski** for coordinating the advertising with all of the newspapers and radio stations in an effort to make our event be well attended. Thank you **Ray Ellingsen** who was ever present when needed. Thank you to the individuals who displayed their collections (see listing in this *Knewslettter*) and the demonstrators (see listing in this *Knewslettter*) who shared their knowledge with the others who attended our event. Thank you to the participants of the handmade knife competition. Thank you to the handmade knifemakers (see listing in this *Knewslettter*) who made the awards for our display winners and special presentations. Thank you **Gene Martin** for your coordination of this event. Thank you **George Filgate** for the photographs which are in this *Knewslettter*. Thank you to the table-holders who made it a most seamless event. Thank you to the members who have provided us with the necessary oomph to continue to have a yearly Show. Thank you to our first time visitors. Hopefully we have created an urge for you to return next year.

Thank you to the officers of our group, **Joshua Hill, Craig Morgan,**

John Priest and Dennis Ellingsen. It is an easier job because we work together.

Thank you **Lane Events Staff (Corey, Gary, Randy, Ron, Sandy and Tim)** for your courteous and helpful responses to our needs. I know that we require special treatment, and you always provide it. We do appreciate it. We did have one elephant in the room that bears discussion. We had been assured that we would have food and coffee service. That was not the case. The lack of courtesy and quality of food was very apparent. I do apologize. We have had discussions with Lane Events since that fiasco, and they are very aware that they did not provide as expected or needed. Negotiations are in the works to resolve this issue for the future.

As you may be aware a number of individuals were presented with handmade paring knives in recognition of their contributions to our organization and event. These are knives that were made from the 2016 blank and enhanced by the custom knifemakers. I was one of those recipients, and I am very appreciative of the knife which I received which was made by **Cameron House**. It will be displayed but will also be used and enjoyed. The other winners of the awards are listed in the article

“Special Presentation Awards.” All are very deserving of the acknowledgment by our organization for their help in coordinating our event. Without our volunteers this event would not happen. Their enthusiasm and selflessness go a long way to present a united front to our visitors.

See you at the last meeting of the 2017 Show Year, May 17, at the Sizzler Restaurant where we can applaud ourselves for the Job Well Done. We will have gatherings at the Sizzler during the summer months but no meetings. Meetings start again in September for the 2018 Show Year.

Don’t forget to pay for your table for 2018 by the December 15, 2017 deadline. It is never too early to reserve your 2018 table. There will be no *Knewslettter* until September, 2017; but an application for the Show is on our website. I can email an application or snail mail one to you if necessary.

Have a glorious and enjoyable summer. See you at the non-meeting June 21 or July 19 or August 16. See you at the December 9 Show in Eugene or the April 6, 7, 8, 2018 Show in Eugene. Best wishes. 🐾





These are the People who help to make the 2017 Oregon Knife Show possible

Officers

Dennis Ellingsen
Elayne Ellingsen
Joshua Hill
Craig Morgan
John Priest

Bob Hergert
Joshua Hill
Howard Hoskins
Dale Larson
Lynn Moore
Dave Rider
Martin Schempp
Dan Westlind

Special

Steve Allely
Cindy Bristol
Glenda Brown
John Brown
Bryan Christensen
Ana Cooper
Tim Cooper
Edward Davis

Grace Mikolyski
Sue Myers
Ole Olson
Chuck Richards
Ed Schempp
Clay Stephens
Lisa Wages
Mark Zalesky

Knewslettters

B.K. Brooks
Martin Drivdahl
Michael Faber
Ted Fitzwater
Stephen Garger
Roy Humenick
Bruce Lanham
Jim Pitblado
Ray Simonson
Merle Spencer
Clay Stephens
Roger Worley
Gary Zalesky
Mark Zalesky

Display Award Knives

John "Slim" Coleman
Theo Eichorn
Steve Goddard
Gary Griffin
Cameron House
Jim Jordan
David Kurt
Gene Martin
Jeff Murrison
Bernard Ortiz
Sterling Radda
Jeremy Spake
Blair Todd
Bryan Wages

Terry Davis
Ray Ellingsen
Peter Faust
George Filgate
Eric Glesser
Sal Glesser
Robert Golden
Bill Harsey
Jim Hayden
Howard Hoskins
Brian Huegel
Steve Huey
Roy Humenick
Dave Jones
Bernard Levine
Robin Lucia
Gene Martin
Sally Martin
Lisa McCranie

Displays

Mike Adamson
Phil Bailey
Jack Birky
Ron Carriveau
Bruce Dollinger
Ted Fitzwater
R. Terry Gail
James Gedlick
Don Hanham
Ed Holbrook
Lhomond Jones
Barbara Kyle
Michael Kyle
Dale Larson
Mareko Maumasi
Jim Pitblado
Dave Schultz

Demonstrations

Martin Brandt
Murray Carter
Bram Frank
Sean Hayes

Special Presentation Award

This year it was decided the Oregon Knife Collectors would recognize the contribution to our organization by several individuals who had contributed to the success of our 2017 Show. The awards that were presented were handmade custom paring knives which were made from the 2016 blanks provided to the makers.

The following is a list of the recipients and the names of the makers of the knives:

Elayne Ellingsen
Cameron House
Grace Mikolyski
Gene Martin

Glenda Brown
Sterling Radda
Ana Cooper
David Kurt

Lisa Wages
Mike Johnston

We, the Board of Directors, and the membership thank them for their contribution to our efforts to provide an educational and fun event for "Anything that goes cut." 



Display Award Knives

We express our appreciation to the custom knifemakers who completed 2016 blade blanks for the 2017 Display Award Knives.

Slim Coleman - Citrus Heights CA
Theo Eichorn - Grants Pass OR
Steve Goddard - Eugene OR
Gary Griffin - Bend OR
Cameron House - Salem OR
Mike Johnston - Forest Grove OR
Jim Jordan - Junction City OR
David Kurt - Molalla OR

Gene Martin - Williams OR
Jeff Murison - North Plains OR
Bernard Ortiz - Brookings OR
Sterling Radda - Grants Pass OR
Jeremy Spake - Portland OR
Blair Todd - Gresham OR
Bryan Wages - Eugene OR

Gene Martin - Williams OR - Event coordinator

**Best Award Knife - Theo Eichorn - Grants Pass OR

Gene Martin has distributed the 2017 Kukri knife blanks (1095 Steel) which will be finished for the 2018 Show. Those individuals are as follows:

Chuck Cook - Dundee OR
Gary Griffin - Bend OR
Cameron House - Salem OR
Jim Jordan - Junction City OR
David Kurt - Molalla OR
Gene Martin - Williams OR
Lynn Moore - Springfield OR

Craig Morgan - Eugene OR
Jeff Murrison - North Plains OR
Bernard Ortiz - Brookings OR
Sterling Radda - Grants Pass OR
Blair Todd - Gresham OR
Bryan Wages - Eugene OR

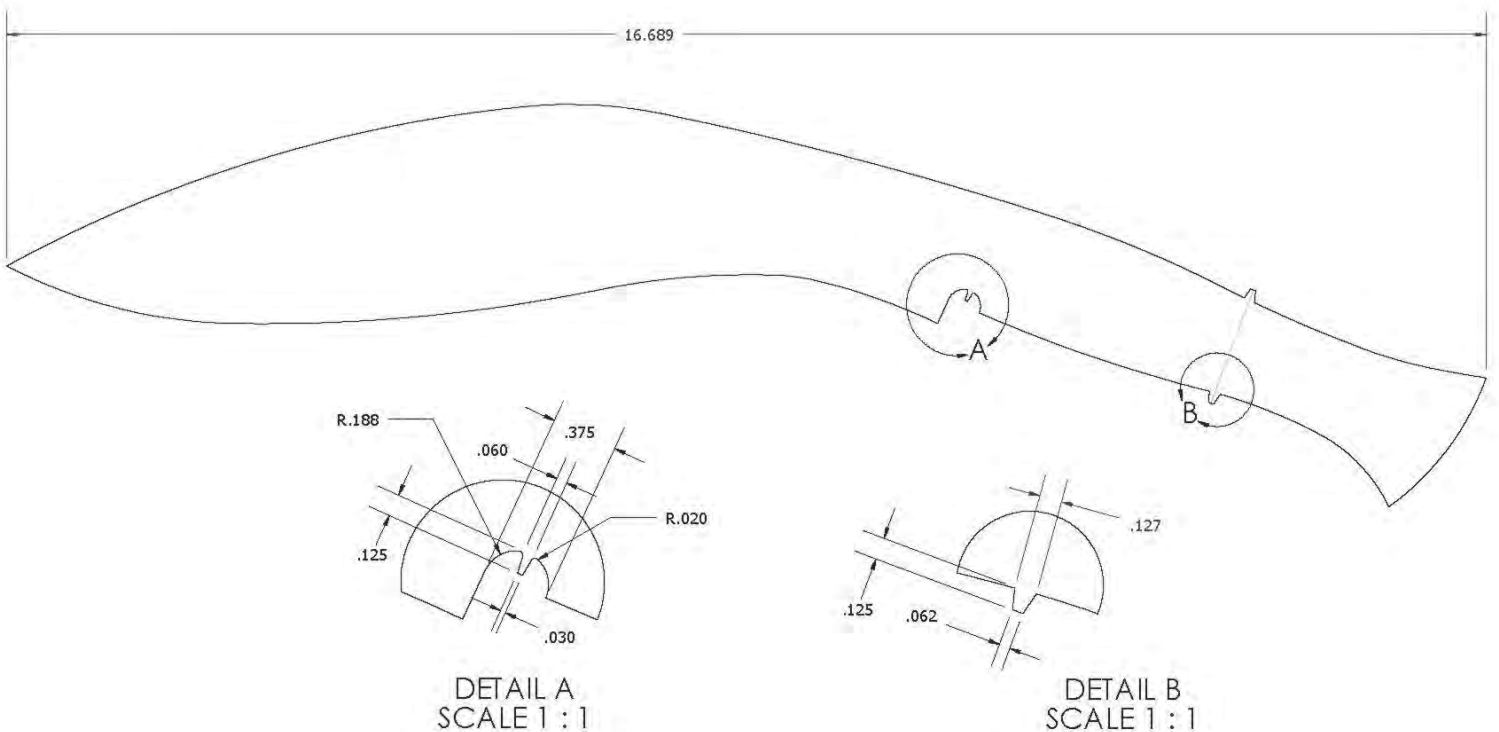



**This will be the last *Knewslettter* until September, 2017.
 Membership is on a calendar year basis.
 Help us by writing articles for the *Knewslettter*.**

The views and opinions implied or expressed herein by authors and advertisers are not necessarily those of the Oregon Knife Collectors Association, its editors, or its officers; and no responsibility for such views will be assumed. The OKCA, its officers and its editors assume no responsibility for claims of advertisers for the quality of goods and services the advertiser provides. The act of mailing or delivering a manuscript or advertisement shall constitute an express warranty on the part of the contributor that the material is original and in no way an infringement upon the rights of others. The act of mailing or delivering a letter or question to the editor shall constitute permission to publish the letter or portion thereof unless the Oregon Knife Collectors Association is informed otherwise in that letter. This Knewslettter is devoted to the general interest of the knife community and does not include personal information such as births, deaths and illness. We also strive to use only material that is directed to the world of cut. Our charter mandates that our mailing list of the membership cannot be sold or used by other than the Oregon Knife Collectors Association.

OKCA Club
Whot-zits & Whos Zits

Craig Morgan
 President (541)345-0152

John Priest
 Vice President (541)517-2029

Elayne Ellingsen
 Sec/Tres. (541)484-5564

Joshua Hill
 Master at Arms (503)580-8998

Dennis Ellingsen
 Show Chairman (541)484-5564

Knewslettter by elayne & dennis
Web page --- <http://www.oregonknifeclub.org>
Club email --- okca@oregonknifeclub.org
Facebook --- [oregon knife collectors association](http://www.facebook.com/oregonknifeclub)

Letters to.....
 OKCA P O Box 2091 Eugene OR 97402

Packages to.....
 OKCA 3003 W 11 Ave PMB 172 Eugene OR 97402

Copyright (C) 2017 Oregon Knife Collectors Association.
 No part of this Knewslettter may be reproduced without permission of the OKCA.
 Layout and printing by instaprint -
 1208 W. 6th - Eugene, OR 97402 -
 Phone (541)686-8591



The Knewslettter
Oregon Knife Collectors Association
PO Box 2091
Eugene, OR 97402

PRESORTED
FIRST-CLASS MAIL
US POSTAGE
PAID
IP

